

How to order

ACTUATOR MODEL	ACTUATION TYPE	SPRING CODE	WORKING TEMPERATURE	COATING
X40	DA=Double Acting	01, 02	P= Normal temp. (-4 °F to 176 °F -20°C to 80°C)	N=C2-02
X50	SR=Spring Return	03, 04	P1=High temp. (-4° F to 250° F -20°C to 120°C)	D=C2-03
X60	DS=Double Acting with SR Cover	05, 06	P2= Low temp. (-40° F to 176° F -40°C to 80°C)	E=C3-03
X75		07, 08		F=C4-03
X90		09, 10		G=C5-03
X115				



Coating Specification

D-F COATING SPECIFICATION					
GRADE	BASE	MIDDLE	TOP	DRY FILM THICKNESS	PROTECTION PERIOD
C2-02	Priming coating*1	-	Finishing coating*1	120µm	5-15 years
C2-03	Priming coating*1	Anti-corrosion coating*1	Finishing coating*1	160µm	over 15 years
C3-03	Priming coating*1	Anti-corrosion coating*1	Finishing coating*2	200µm	over 15 years
C4-03	Priming coating*1	Anti-corrosion coating*1	Finishing coating*2	280µm	over 15 years
C5-03	Priming coating*1	Anti-corrosion coating*1	Finishing coating*3	320µm	over 15 years



THERE ARE BIG ADVANTAGES TO THINKING SMALL

WHY SMALLER IS BETTER

The All Torque Pneumatic Actuator Series 4x4 packs more than double the torque of conventional rack and pinion actuators. That is because it has four pistons generating torque around a centrally located pinion. With more pistons in the actuator, it allows their diameter to be smaller while generating higher torque. At the same time, it means the size of the actuator can be more compact.



WHY SMALLER IS BETTER

With four small cylinders each located on one of four sides of the unit and at a given air pressure, the 4x4 produces the same torque output as double piston models using smaller diameter pistons and a narrower pinion. Thanks to the narrower pinion, the pistons travel shorter distances so that they can move faster from one position to the next.

WHY SMALLER REDUCES AIR CONSUMPTION

The cube shape coupled with pistons traveling shorter distances minimizes size requirements while maximizing torque output. At the same time, shorter piston travel and compact size greatly reduces pressure requirements compared to other designs and results in reduced energy expenditures.



WHY SMALLER IS A BETTER SOLUTION

Because of the four-cylinder design, the 4x4 has many more spring combination possibilities than double piston actuators. This means better solutions under any air pressure requirement. Each chamber can use up to three different spring sizes which nest between the covers and pistons and align by centering rings. Also, springs are wound in opposite directions to avoid tangles during operation.



WHY SMALLER IS STRONGER

For superior corrosion resistance, the body and covers are anodized internally and externally. Plus, they have an external epoxy base layer and a second polyurethane paint to further reduce corrosion in demanding applications. Extended spray wash downs do not create corrosion problems for the actuator.

02

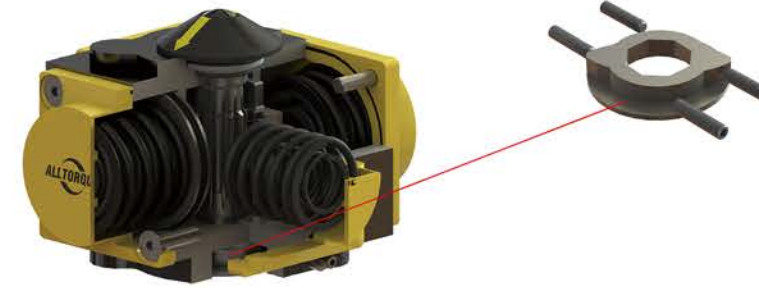

Travel stops can be adjusted by four studs at the base of the actuator. The studs are opposed from each other so no unequal forces are generated, the stop design allows for $\pm 5^\circ$ adjustment in both opening and closing rotations. Mid-stroke stop points can be achieved with longer studs.

Blowout proof and POM support pad in body maintains proper contact of the piston racks to the pinion at all times



Nested springs are aligned by rings cut in the piston face and end cap. This ensures correct orientation. With four cylinder areas, many different combinations are available allowing for correct sizing.

03

GENERAL FEATURES



- All Torque ® 4 x4 utilizes carbon steel pistons that allow for higher cycles because of their greater strength.
- The pistons travel half short distance than double piston models, so that the life of seals is increased more than doubled.
- Different sealing material selection applicable for temperature range from -40°C to 120°C
- Piston bearing made of material with low friction coefficient to avoid metal to metal contact. Easily replaceable for maintenance.
- Double lower drilling for valve mounting, and centering, according to ISO 5211/DIN 3337 standards.
- Independent bi-directional travel stop adjustment +/- 5° ensuring precise positioning in all flow control services , adjustable between 85°- 95° rotation.
- Direct mounted solenoid connections according to NAMUR standards. Lower female shaft key, according to ISO 5211/DIN 3337 standards, for assembly on valves with star or square shaft.
- Air supply: can be dry or lubricated filtered compressed air.
- The lubrication carried out by the manufacturer qualifies for a minimum of 1,000,000 operations.
- All Torque 4X4 provides various corrosion protection grades to adapt to different application environments according to a standard painting management system D-F complies to ISO / EN 12944. All products of All Torque have adopted DF coating specifications C2 - 02 and optimized multi-layer painting method is used in each enclosure to achieve the best corrosion resistance. Different colors and more alternative protection solutions are also available.
- Visual position indicator the 4 x 4 actuators are supplied as standard.
- The indicator designed to remain on the actuator for continuous indication when limit switch is being used.

PARTS AND IDENTIFICATION

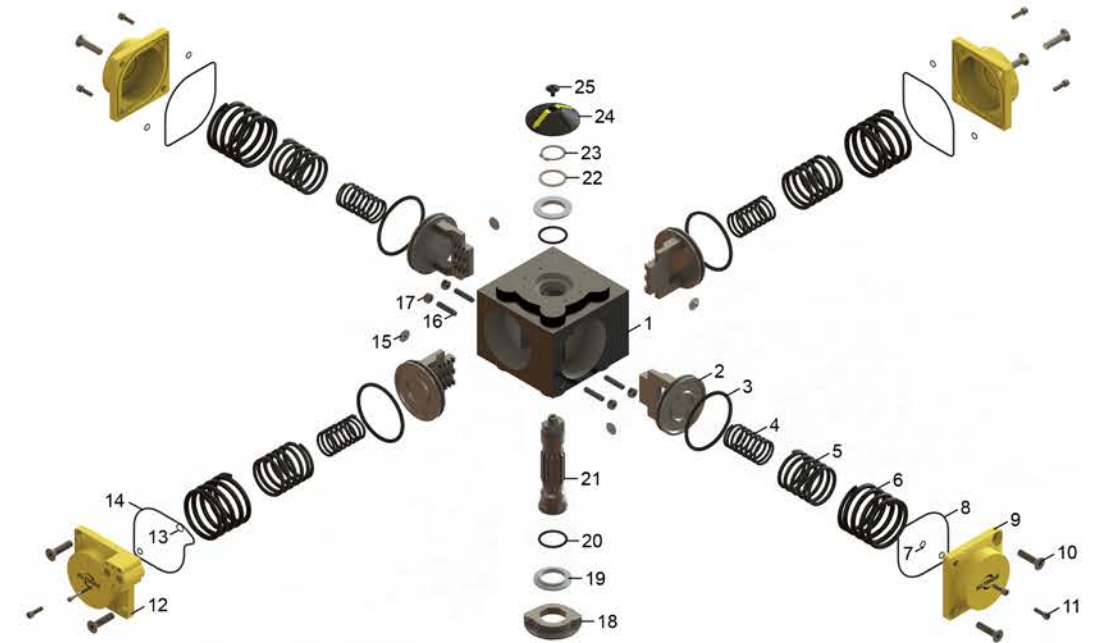

PART NO.	QTY.	PART DESCRIPTION	MATERIAL
1	1	Body	Casting aluminium alloy
2	4	Piston	Carbon steel
3	4	O ring	NBR
4	Max 4	Inner spring	Spring steel
5	Max 4	Middle spring	Spring steel
6	Max 4	Outer spring	Spring steel
7	7 for size 090 8 for size 115 0 for rest sizes	O ring	NBR
8	3 4 for size 115	O ring	NBR
9	3 4 for size 115	Side cap	Casting aluminium alloy
10	8	Socket countersunk head screw	Stainless steel 304
11	8 for size 090 10 for size 115 0 for rest sizes	socket head cap screw	Stainless steel 304
12	1	Air connecting cap	Casting aluminium alloy
13	1 2 for size 115	O ring	NBR
14	1 0 for size 115	O ring	NBR
15	4	Bearing Pad	POM
16	4	socket set screw	Stainless steel 304
17	4	Nut	Stainless steel 304
18	1	Stroke adjustment stop	CF8
19	2	Bearing	POM
20	2	O ring	NBR
21	1	Gear shaft	Carbon steel
22	1	Washer	Stainless steel 304
23	1	Snap ring	Stainless steel 304
24	1	Indicator	ABS
25	1	Screw	Carbon steel

OPERATIONS

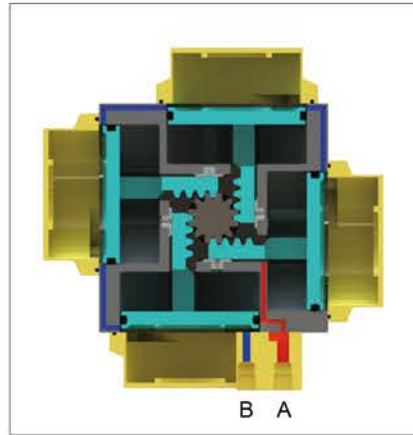

Air supplied to Port A which is connected to the center chambers forces piston apart toward end position with exhaust air exiting at Port B (a counterclockwise rotation is obtained).

Air supplied to Port B which is connected to the four chambers forces piston toward center with exhaust air exiting at Port A (a clockwise rotation is obtained).

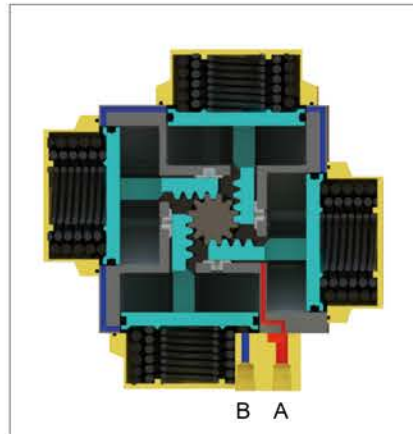
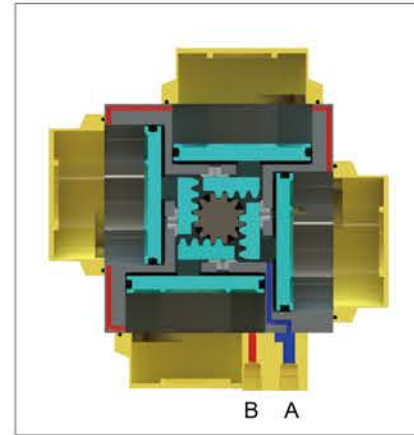

Air supplied to Port A which is connected to the center chamber forces piston apart and toward end position compressing springs, with exhaust air exiting at Port B (a counterclockwise rotation is obtained).

Release of air allows springs to force pistons toward center position with exhaust air exiting at Port A (a clockwise rotation is obtained).

ACTUATION SIZING GUIDE

The seat material used, media, temperature, frequency of operation and critical application of the valve's operation are all important factors in calculating the actuation needs of a given valve. The information provided below should be considered as a guide only and must be adjusted according to experience and judgement. Proper actuator selection is required to prevent valve or process equipment damage as well as proper valve operation.

For determining torque we assume that valve torque results from the friction between the ball and seats as well as the stem and stem seals.

Valve Torque

The torque requirements of ball valves will vary depending on several factors

- **Seat design and material**

The seat friction force depends on the seat material and the applicable service factor multipliers shown in the chart below.

- **Stem Seal**

Torque results from the stem contact with stem seals and the type of packing materials affect torque. Stem seal torque needs to be considered as a percentage of overall torque especially in small valve sizes.

Service Conditions To Consider

- Differential Pressure
- Frequency of Operation
- Media Influence
- Temperatures
- Cycle Time
- Instrument Air Supply

Minimum and maximum pressures
Stuck valve torque
Slurries, dry gases, oils
Minimum and maximums
Line hammer, process requirements
Peak demand pressure availability

Media and Service Factor

To establish minimum torque requirements, multiply valve torque by the following application media and service factors

Additional 1.25 safety efficiency must be considered when select the actuator size.

Media Factor	Multipl ier	Service Factor	Multipl ier
Clean particle free , non-lubricating (Water , alcohol or solvents)	1.00	Simple on and off Operations	1.00
Clean particle free , lubricating oil	0.80	Throtting	1.20
Slurries or heavily corroded and contaminate systems	1.30 to 2.00	Positioner Control	1.50
Gas or saturated steam , clean and wet	1.00	Once per day session	1.20
Gas or superheated steam , clean and dry	1.30	Once every two days or more or plant critical	1.50
Gas , dirty unfiltered e.g.natural gas , chlorine	1.20 to 1.50		

Double Acting Actuator (DA)

In the double acting actuators, the control pinion rotation and its reversal are obtained by reversing the supply to the two input ports. The output torques obtainable mainly depend on the cylinder diameter and the supply pressure; by increasing one or both factors, the available torque also increases. As shown in diagram A, the torque of a DA actuator is constant throughout the entire rotation and relevant reversal. The normal advised safety factor, in addition to the stated valve manufacturer torque, is 1.2.

*Select the actuator size whose torque output at given pressure exceeds the valve torque and application factor.

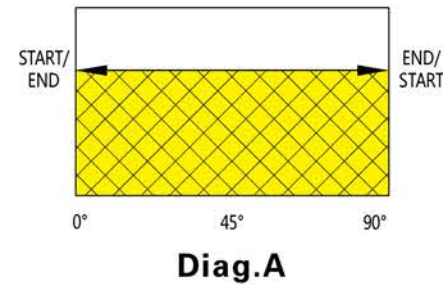

Diag.A

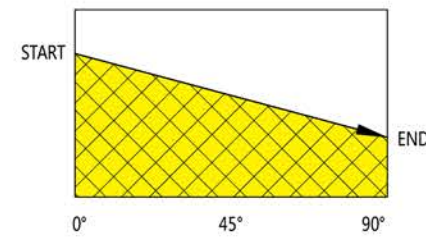

Diag.B

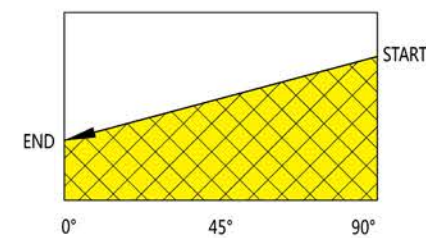

Diag.C

Spring Return Actuator (SR)

In these type of actuators, which utilize springs for reversing the rotation of the control pinion, the output torque depends not only on the cylinder diameter and the supply pressure, but also on the presence of the springs, which should be compressed to guarantee the return. As shown in diagram B, the available torque at 0° progressively reduces during the rotation due to the springs' compression. On the contrary, as shown in diagram C, the torque starting from the 90° position constantly decreases until 0° because of spring extension. Owing to the higher friction present, the safety coefficient in this case is advised 1.25.

*Select the actuator whose torque output at 0° and 90° at a given air pressure exceeds the valve torque.

Ball Valve

Ball valve construction concept is based essentially on a polished ball (including a through port) contained in two seats (upstream and downstream). The ball rotation allows the flow, or stops the flow through the valve. Differential pressure between upstream and downstream pressure forces the ball against the downstream seat (floating ball). In this case, the valve torque is generated by the friction between ball and seat and also between stem and packing. As shown in the diagram to the right, the highest torque point is when, in presence of pressure, the valve is in the closed position, and passes to the open position (breakaway torque).

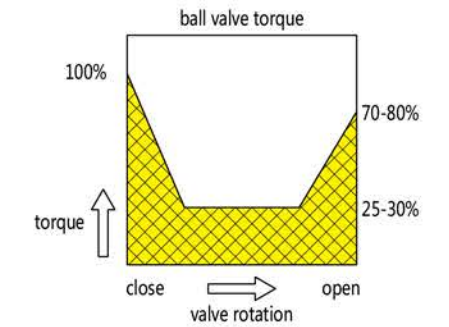

Butterfly Valve

Butterfly valve construction concept is based essentially on a disc fixed on an axis, which in the closed position, is completely contained by the seat. The open position is obtained when, with a rotation, the disc (through its stem) becomes parallel to the flow. On the contrary, the closed position is obtained when the disc is perpendicular to the flow. In the case of the butterfly valve, the torque is generated by the friction between the disc and the seat, by the stem packing and also by the differential pressure that forces on the disc. The highest torque point, as shown in the diagram, is in the closed position, and only after a small rotation it is considerably reduced.

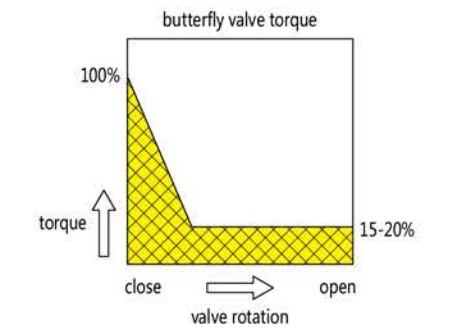

Plug Valve

Plug valve construction concept is based essentially on a male (plug) contained in a female cone (seat). The plug provides a through port in one direction and with its rotation into the seat the opening and closure of the valve is obtained. The torque is usually not influenced by the flow pressure, but is generated essentially by the friction between the seat and the plug, during the opening closing cycle. As shown in the diagram to the right, the highest torque point is in the closed position and remains high for the rest of the operation, because the torque is not influenced by pressure.

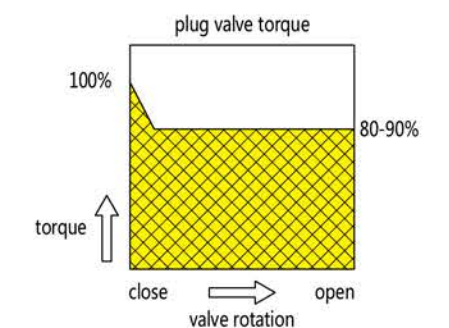

TORQUE RATING

DOUBLEACTING							
Air Supply Pressure in PSI	40	60	70	80	90	100	120
Actuator Model							
X40	89	133	156	178	200	222	267
X50	162	243	283	324	264	405	486
X60	299	448	523	598	672	747	896
X75	489	734	856	978	1100	1223	1467
X90	896	1344	1568	1791	2016	2240	2688
X115	1665	2498	2914	3330	3747	4163	4995

Imperial Unit in-lb

Size	Air Supply Pressure in PSI	40		60		70		80		90		100		120		Spring Stroke	
		START	END	START	END	START	END	START	END	START	END	START	END	START	END	START	END
X40	SR1	53	27	98	71	120	94	142	116	165	138	187	160	231	205	62	36
	SR2	41	6	86	51	108	73	130	95	153	117	175	140	219	184	83	48
	SR3			68	20	90	42	112	64	135	86	157	109	201	153	114	65
	SR4					72	11	95	33	117	55	139	78	184	122	145	83
X50	SR3	108	68	189	149	229	189	270	230	310	270	351	311	432	392	94	54
	SR4	97	49	178	130	218	170	259	211	299	251	340	292	421	373	113	65
	SR5	75	11	156	92	197	133	237	173	278	214	318	254	399	335	151	87
	SR6			135	55	175	95	216	136	256	176	297	217	378	298	188	108
	SR7					164	76.3	205	117	245	157	286	198	367	279	207	119
	SR8					154	57.4	194	97.9	235	138	275	179	356	260	226	130
	SR9					143	38.6	183	79.1	224	120	264	160	345	241	245	141
	SR10							172	60.3	213	101	253	141	334	222	264	152
	SR3	199	125	348	274	423	349	498	424	572	499	647	573	796	723	174	100
	SR4	179	90	328	240	403	314	478	389	552	464	627	538	776	688	208	120
X60	SR5	139	21	288	170	363	245	438	320	512	394	587	469	736	618	278	160
	SR6			248	101	323	175	398	250	473	325	547	400	697	549	347	200
	SR7					303	141	378	215	453	290	527	365	677	514	382	220
	SR8					283	106	358	181	433	255	507	330	657	479	417	240
	SR9					263	71.2	338	146	413	221	487	295	637	445	452	260
	SR10							318	111	393	186	467	261	617	410	486	280
	SR3	326	205	570	449	692	572	815	694	937	816	1,059	938	1,304	1,183	284	163
	SR4	293	148	537	392	660	515	782	637	904	759	1,027	882	1,271	1,126	341	196
	SR5	228	34	472	279	594	401	717	523	839	645	961	768	1,206	1,012	455	261
	SR6			407	165	529	287	651	409	774	532	896	654	1,140	899	569	327
SR7					496	230	619	353	741	475	863	597	1,108	842	626	360	
SR8					464	174	586	296	708	418	830	540	1,075	785	682	392	
SR9					431	117	553	239	675	361	798	483	1,042	728	739	425	
SR10							520	182	643	304	765	427	1,010	671	796	458	
X75	SR3	596	375	1,044	823	1,268	1,047	1,492	1,270	1,716	1,495	1,940	1,719	2,388	2,167	521	299
	SR4	537	271	984	719	1,208	943	1,432	1,166	1,656	1,391	1,880	1,615	2,328	2,063	625	359
	SR5	417	63	865	510	1,089	734	1,312	958	1,537	1,182	1,761	1,406	2,209	1,854	833	479
	SR6			745	302	969	526	1,192	749	1,417	974	1,641	1,198	2,089	1,646	1,042	599
	SR7					909	422	1,132	645	1,357	870	1,581	1,094	2,029	1,542	1,146	659
	SR8					849	318	1,073	541	1,297	766	1,521	990	1,969	1,438	1,250	718
	SR9					789	214	1,013	437	1,237	661	1,461	885	1,909	1,333	1,354	778
	SR10							953	333	1,177	557	1,401	781	1,849	1,229	1,458	838
	SR3	1,109	697	1,941	1,530	2,357	1,946	2,774	2,362	3,190	2,778	3,606	3,195	4,439	4,027	968	556
	SR4	997	503	1,830	1,336	2,246	1,752	2,662	2,169	3,079	2,585	3,495	3,001	4,328	3,834	1,162	668
SR5	775	116	1,607	949	2,024	1,365	2,440	1,781	2,856	2,198	3,272	2,614	4,105	3,446	1,549	890	
SR6			1,385	562	1,801	978	2,217	1,394	2,634	1,810	3,050	2,227	3,882	3,059	1,936	1,113	
SR7					1,690	784	2,106	1,200	2,522	1,617	2,939	2,033	3,771	2,866	2,130	1,224	
SR8					1,578	591	1,995	1,007	2,411	1,423	2,827	1,839	3,660	2,672	2,323	1,335	
SR9					1,467	397	1,883	813	2,300	1,230	2,716	1,646	3,549	2,478	2,517	1,447	
SR10							1,772	620	2,188	1,036	2,605	1,452	3,437	2,285	2,711	1,558	

TORQUE RATING

DOUBLEACTING							
Air Supply Pressure in BAR	3	4	5	5.5	6	7	8
Actuator Model							
X40	11	15	18	20	22	26	29
X50	20	27	33	37	40	46	53
X60	37	49	61	67	73	86	98
X75	60	80	100	110	120	140	160
X90	110	147	184	202	220	257	294
X115	205	273	341	375	409	477	546

Metric Unit Nm

Size	Air Supply Pressure in PSI	40		60		70		80		90		100		120		Spring Stroke	
		START	END	START	END	START	END	START	END	START	END	START	END	START	END	START	END
X40	SR4	7	4	11	8	14	11	16	13	18	15	21	18	25	22	7	4
	SR5	6	2	9	5	13	9	15	11	17	13	20	16	24	20	9	5
	SR7			7	2	11	5	13	7	15	9	18	13	22	16	13	7
	SR10					9	2	11	4	12	6	16	9	20	13	16	9
X50	SR3	14	9	20	16	27	23	30	26	34	29	40	36	47	42	11	6
	SR4	13	7	19	14	26	20	29	24	32	27	39	34	46	40	13	7
	SR5	10	3	17	10	23	16	27	19	30	23	37	29	43	36	17	10
	SR6			14	5	21	12	24	15	28	19	34	25	41	32	21	12
	SR7					20	10	23	13	26	16	33	25	40	30	23	13
	SR8					18	8	22	11	25	14	32	21	38	28	26	15
	SR9					17	6	21	9	24	12	31	19	37	25	28	16
	SR10							19	7	23	10	29	17	36	23	30	17
	SR3	25	17	38	29	50	42	56	48	62	54	74	66	87	78	20	11
	SR4	23	13	35	25	48	38	54	44	60	50	72	62	84	74	24	14
X60	SR5	19	5	31	18	43	30	49	36	55	42	68	54	80	67	31	18
	SR6			26	10	39	22	45	28	51	34	63	46	75	59	39	23
	SR7					36	18	42	24	49	30	61	43	73	55	43	25
	SR8					34	14	40	20	46	26	59	39	71	51	47	27
	SR9					32	10	38	16	44	22	56	35	69	47	51	29
	SR10							36	12	42	18	54	31	66	43	55	32
	SR3	42	28	62	48	82	68	92	78	102	88	122	108	142	128	32	18
	SR4	38	22	58	42	78	62	88	72	98	82	118	102	138	122	39	22
	SR5	31	9	51	29	71	49	81	59	91	69	111	89	131	109	51	30
	SR6			43	16	63	36	73	46	83	56	103	76	123	96	64	37
SR7					60	30											

SPRING ARRANGEMENT

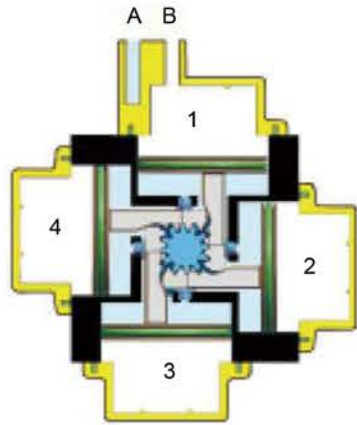

*No outer spring for model X40.

SPRING SETS CODES	SPRING POSITION	CHAMBER1	CHAMBER2	CHAMBER2	CHAMBER2
1	Inner Spring	√	√	√	√
	Middle Spring	-	-	-	-
	Outer Spring	-	-	-	-
2	Inner Spring	-	-	-	-
	Middle Spring	√	√	√	√
	Outer Spring	-	-	-	-
3	Inner Spring	√	-	√	-
	Middle Spring	√	√	√	√
	Outer Spring	-	-	-	-
4	Inner Spring	√	√	√	√
	Middle Spring	√	√	√	√
	Outer Spring	-	-	-	-
5	Inner Spring	√	√	√	√
	Middle Spring	-	√	-	√
	Outer Spring	√	-	√	-
6	Inner Spring	√	√	√	√
	Middle Spring	-	-	-	-
	Outer Spring	√	√	√	√
7	Inner Spring	√	-	√	-
	Middle Spring	-	√	-	√
	Outer Spring	√	√	√	√
8	Inner Spring	-	-	-	-
	Middle Spring	√	√	√	√
	Outer Spring	√	√	√	√
9	Inner Spring	√	-	√	-
	Middle Spring	√	√	√	√
	Outer Spring	√	√	√	√
10	Inner Spring	√	√	√	√
	Middle Spring	√	√	√	√
	Outer Spring	√	√	√	√

TECHNICAL DATA

	SIZE	X40	X50	X60	X75	X90	X115
Weight of Double Acting	Lb	2.39	3.86	6.81	10.69	16.42	28.66
	Kg	1.08	1.75	3.09	4.85	7.45	13.00
Weight of Double Acting With SR Cover (DS)	Lb	2.42	3.96	6.97	10.16	17.17	29.78
	Kg	1.10	1.80	3.16	5.06	7.79	13.51
Code of Spring Return	Weight of Spring Return Actuator						
01	Lb	2.51	x	x	x	x	x
	Kg	1.41	x	x	x	x	x
02	Lb	2.60	x	x	x	x	x
	Kg	1.18	x	x	x	x	x
03	Lb	2.67	4.17	7.50	12.19	18.92	33.27
	Kg	1.21	1.89	3.10	5.52	8.58	15.09
04	Lb	2.73	4.321	7.58	12.35	19.22	33.91
	Kg	1.24	1.91	3.11	5.60	8.72	15.38
05	Lb	x	4.30	7.76	12.63	19.69	34.55
	Kg	x	1.95	3.52	5.73	8.93	15.67
06	Lb	x	4.39	7.94	12.92	20.15	35.19
	Kg	x	1.99	3.60	5.86	9.14	15.96
07	Lb	x	4.43	7.98	13.07	20.9	35.98
	Kg	x	2.01	3.62	5.93	9.25	16.32
08	Lb	x	4.52	8.20	13.41	20.92	36.77
	Kg	x	2.05	3.78	6.11	9.49	16.68
09	Lb	x	4.56	8.29	13.62	21.25	37.41
	Kg	x	2.07	3.76	6.18	9.64	16.97
10	Lb	x	4.63	8.38	13.78	21.56	38.03
	Kg	x	2.10	3.80	6.25	9.78	17.25
Air Consumption per stroke ** Actual Volume-Litre	CCW	0.08	0.15	0.29	0.47	0.80	1.3
	CW	0.11	0.19	0.39	0.64	0.95	1.3
	Total	0.19	0.34	0.64	1.11	1.75	2.6
Air Consumption per stroke ** Actual Volume-in ³	CCW	4.9	9.2	16.2	28.7	46.3	79.3
	CW	6.7	11.6	21.3	35.1	52.3	82.6
	Total	11.6	20.7	37.5	63.8	98.6	161.9
Opening Time DA *	Sec.	0.15	0.21	0.39	0.53	1.10	1.60
Closing Time DA *	Sec.	0.16	0.24	0.41	0.54	1.30	1.80

* The above indicated moving time of the actuator, are obtained in the following testcons: (1) Room Temperature. (2) Actuator Stroke 90° (3) Solenoid Valve with orifice of 4mm and flow capacity Qn 400/ L/min. (4) Inside pipe diameter 8mm, (5) Medium clean air, (6) Air supply pressure 5.5 bar (79, 75psi), (7) Actuator without external resistance load. Cautions: on the field applications when one or more of the above parameters are different, the moving time will be different.

Accessory Top Mount NAMUR Standard VDINDE 3845 Bottom Mount ISO 5211

Working Temperature		
NBR	-20° C to 80° C	-4° F to 176° F
Fluorine rubber	-20° C to 120° C	-4° F to 250° F
Improved NBR	-40° C to 80° C	-40° F to 176° F
Working Pressure		
DA	20 to 120 PSI	1.5 to 8 bar
SR	30 to 120 PSI	2.0 to 8 bar

TOP VIEW

BOTTOM VIEW

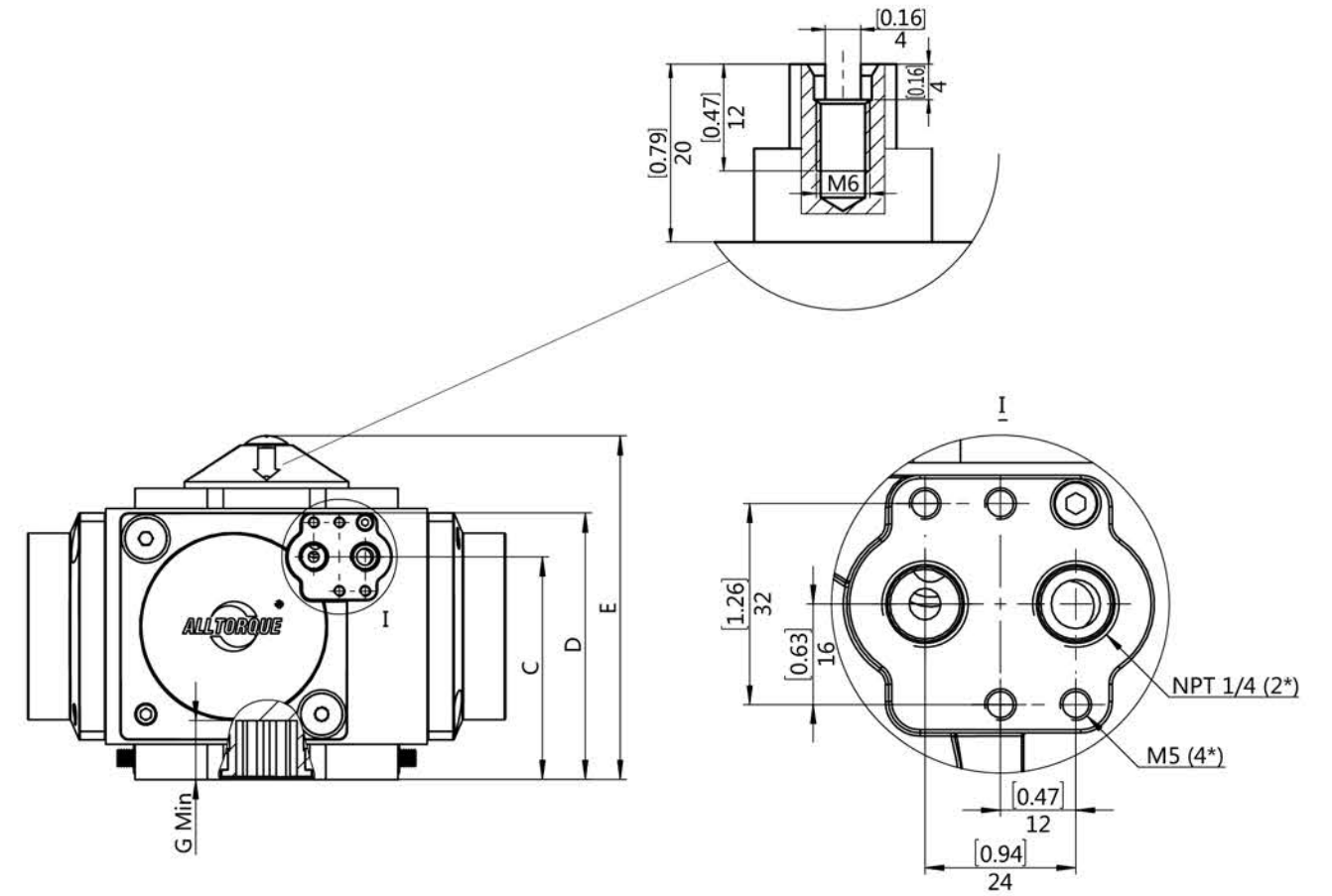
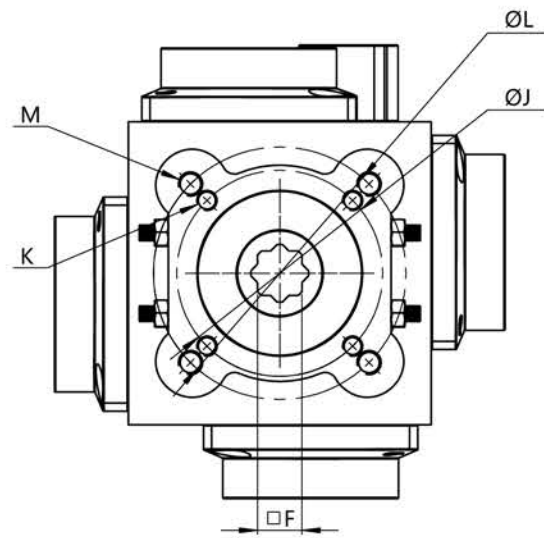
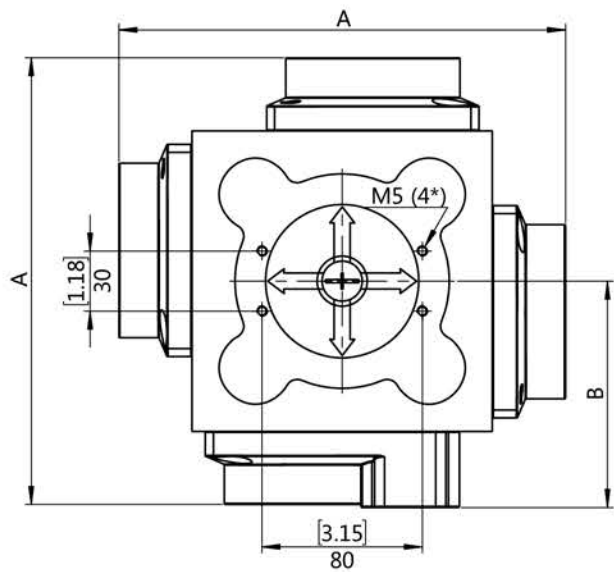

SIZE	A		B		C		D		E	
	mm	inch	mm	inch	mm	inch	mm	inch	mm	inch
X40	110.0	4.33	66.0	2.60	51.7	2.04	69.1	2.73	92.5	3.65
X50	135.6	5.34	77.4	3.05	63.4	2.50	80.0	3.15	103.5	4.08
X60	164.0	6.46	89.5	3.52	76.6	3.02	98.0	3.86	120.0	4.73
X75	199.0	7.83	95.0	3.74	93.1	3.67	118.0	4.65	138.5	5.46
X90	224.0	8.82	114.0	4.49	102.5	4.04	136.0	5.36	156.5	6.17
X115	274.0	10.79	112.0	4.41	119.2	4.70	165.0	6.50	189.0	7.45

SIZE	F		G		J		K	L		M
	mm	inch	mm	inch	mm	inch	mm	mm	inch	mm
X40	9.0	0.35	14.0	0.56	50	1.97	M6	/	/	/
X50	11.0	0.43	15.5	0.62	50	1.97	M6	70	2.76	M8
X60	14.0	0.55	19.5	0.77	70	2.76	M8	102	4.02	M10
X75	17.0	0.67	22.5	0.89	70	2.76	M8	102	4.02	M10
X90	22.0	0.87	26.5	1.05	102	4.02	M10	/	/	/
X115	27.0	1.06	32.5	1.28	125	4.92	M12	/	/	/